



UNIVERSAL APPLIANCE JACKET

PRODUCT

6" JACKET DIVIDER
BOX PANEL

Item No. SUNJKDIV6

DESCRIPTION

6" JACKET DIVIDER BOX PANEL
FOR CREATING JACKET
COMBINATIONS WITHIN A
SINGLE CUT-OUT

PRODUCT DIMENSIONS

6" WIDTH x 14-1/4"
HEIGHT x 25-3/4"
DEPTH

CUT-OUT DIMENSIONS

ADD ADDITIONAL 2-1/4"
TO CUTOUT FOR ANY
TWO JACKET
COMBINATIONS

SUPPORT

TECH SUPPORT
888-934-9449
WWW.SUNSTONEMP.COM

PRODUCT DIMENSIONS

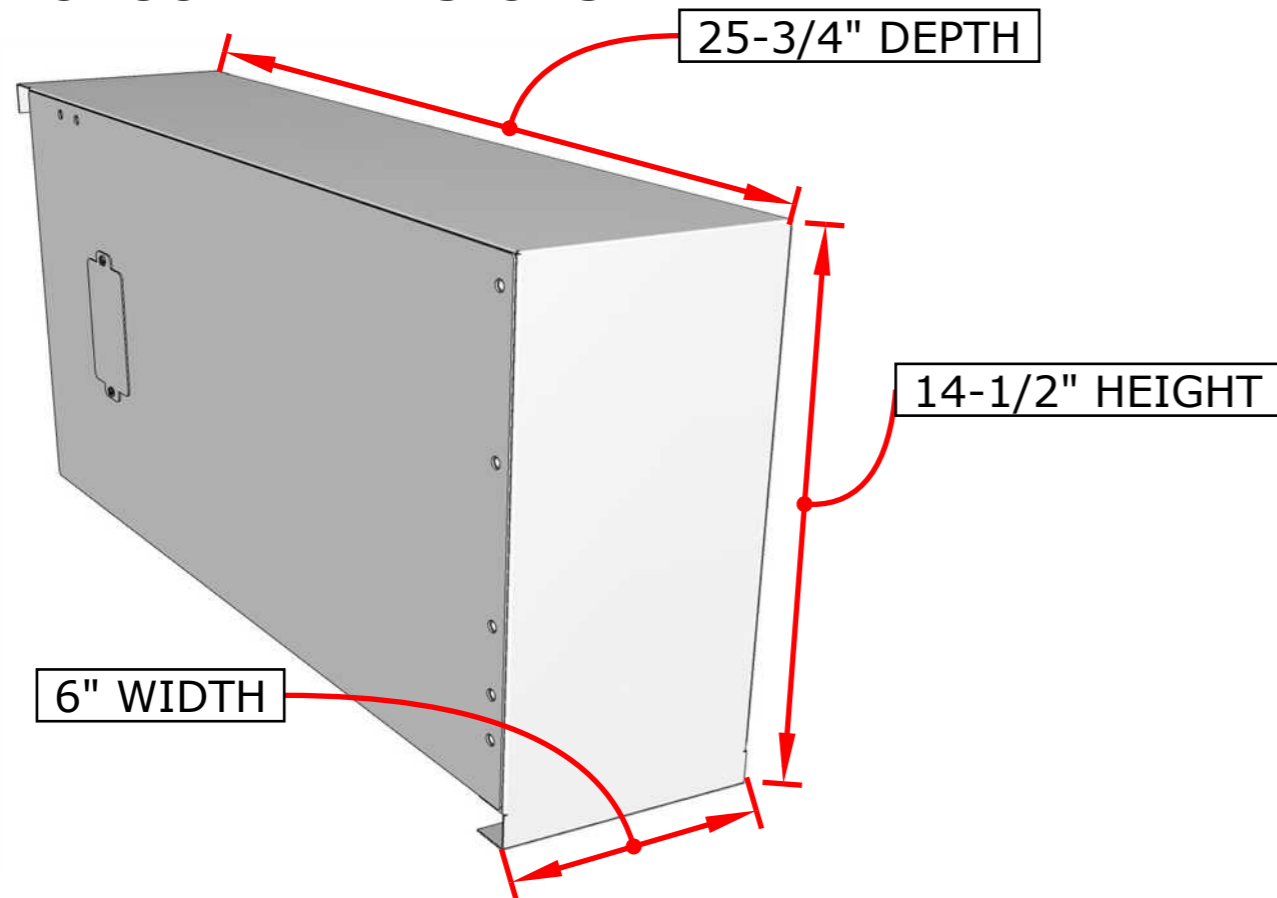

CUT-OUT DIMENSIONS

ADD ADDITIONAL 2-1/4" TO ANY TWO JACKET
COMBINATIONS, OR DOUBLE THIS LENGTH FOR
ANY THREE JACKETS

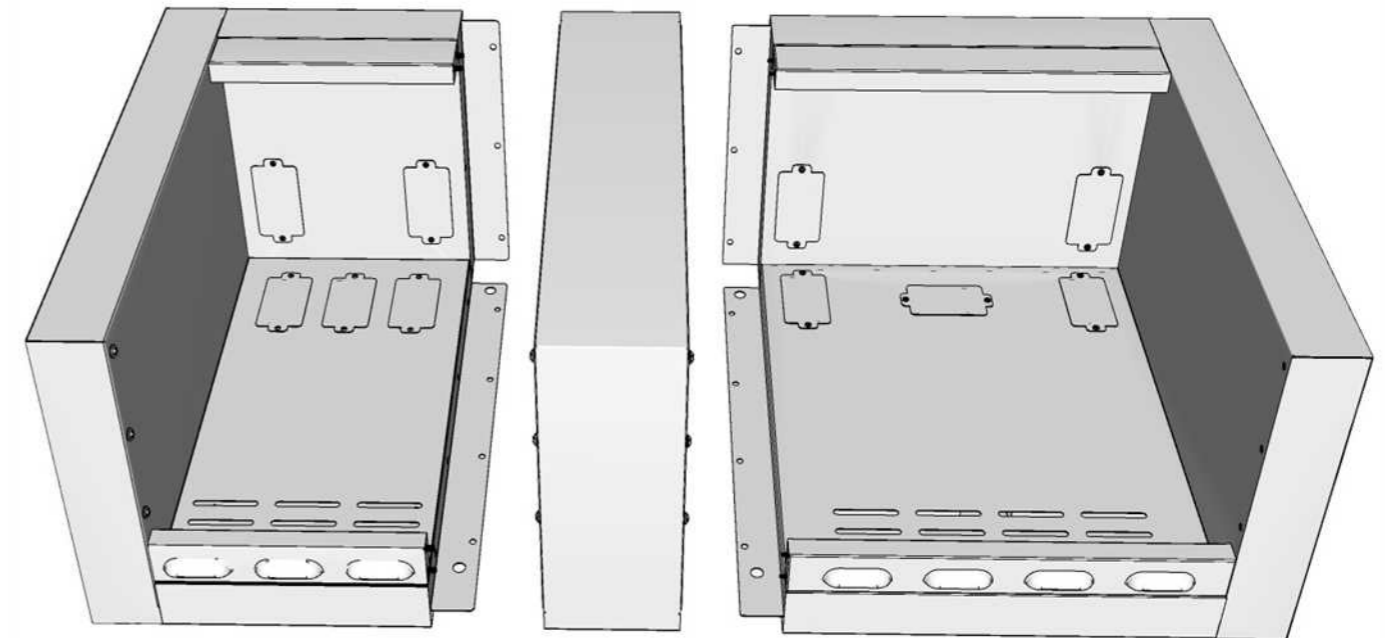

CONNECT DIVIDER BETWEEN "ANY" TWO
OPPOSING APPLIANCE JACKETS

DIVIDER BOX SETUP

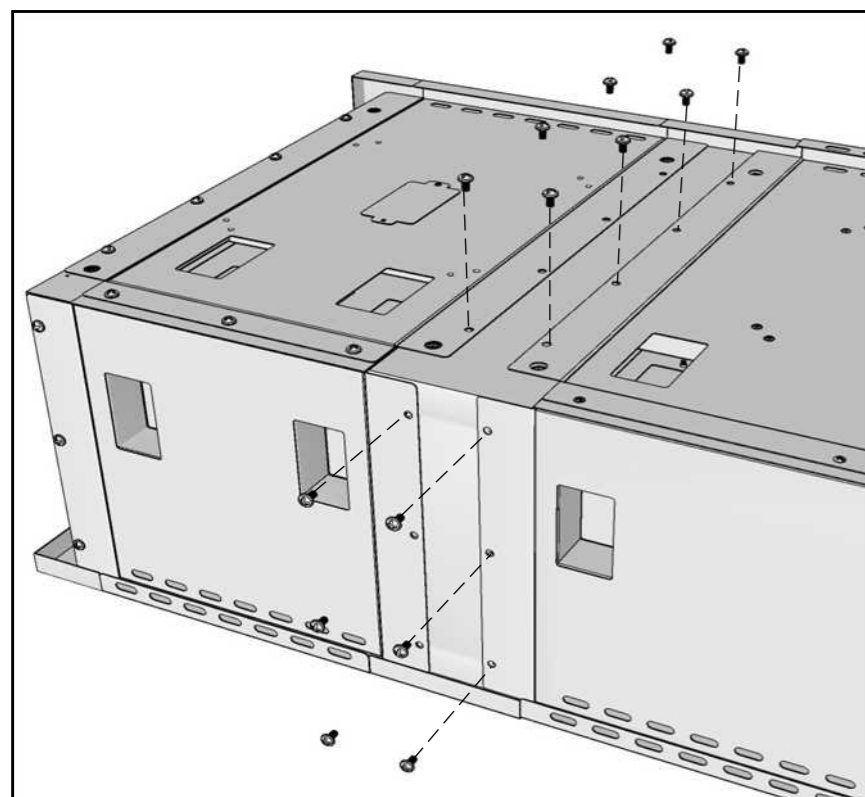

1. Place SUNJKDIV6 upside down
2. Slide each adjoining jacket over divider box panel, each jacket mounting flange overlaps the divider.
3. Screw in all provided screws, which are included with unused jacket side panel.
4. Be sure all screws are tightened down securely, then flip entire connected jackets right side up.

JACKET PANEL INSTALL

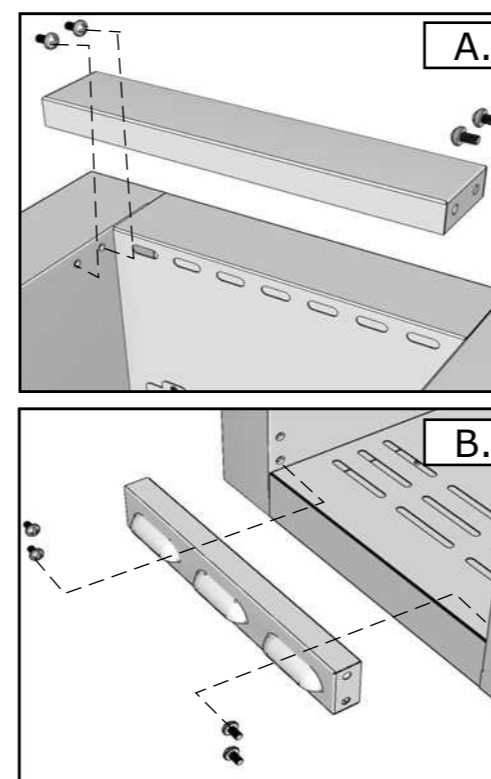

If using any Burner Jackets, these have an additional back support panel, which can be installed between with jacket side panel and the adjacent divider box side.

Mount the lower front vent panel between each jacket side and center divider box panel.