

# ARUBA SERIES ODK COMPONENTS

## PRODUCT

30" Double Access Door

Item No. ARU-DD30

## DESCRIPTION

30" Aruba Series Double Door, works best w/appliance between 28" to 33" Width

## PRODUCT DIMENSIONS

**Product Size:** 30" WIDTH x 20-1/2" HEIGHT x 1-3/4" DEPTH  
**Cut-Out Size:** 28-1/8" WIDTH x 19" HEIGHT x 2-1/4" DEPTH

## SPECIFICATIONS

304 Stainless Steel Construction Frame, Doors

## WARRANTY

3 YEARS STRUCTURE WARRANTY AGAINST MANUFACTURE DEFECTS

### Product Dimensions

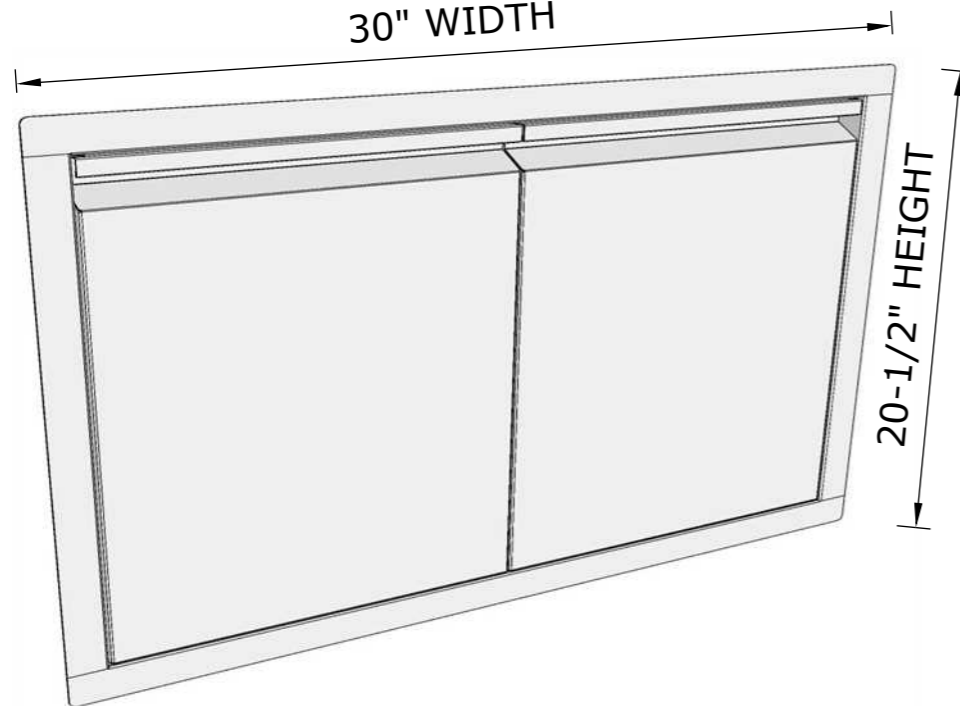

### Product Features

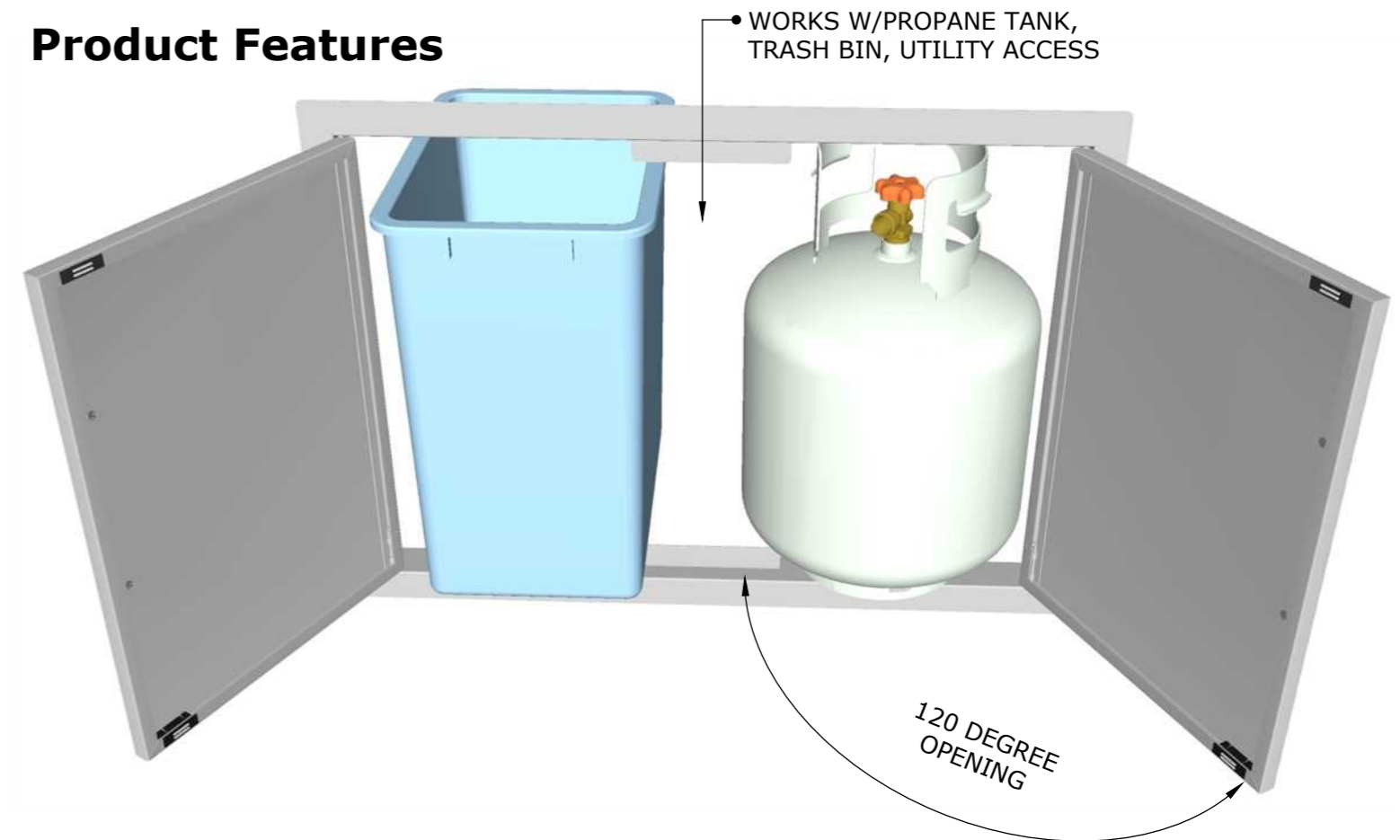

ISLAND WALL CUT-OUT SIZE:  
28-1/8" WIDTH x 19" HEIGHT x 2-1/4" Depth

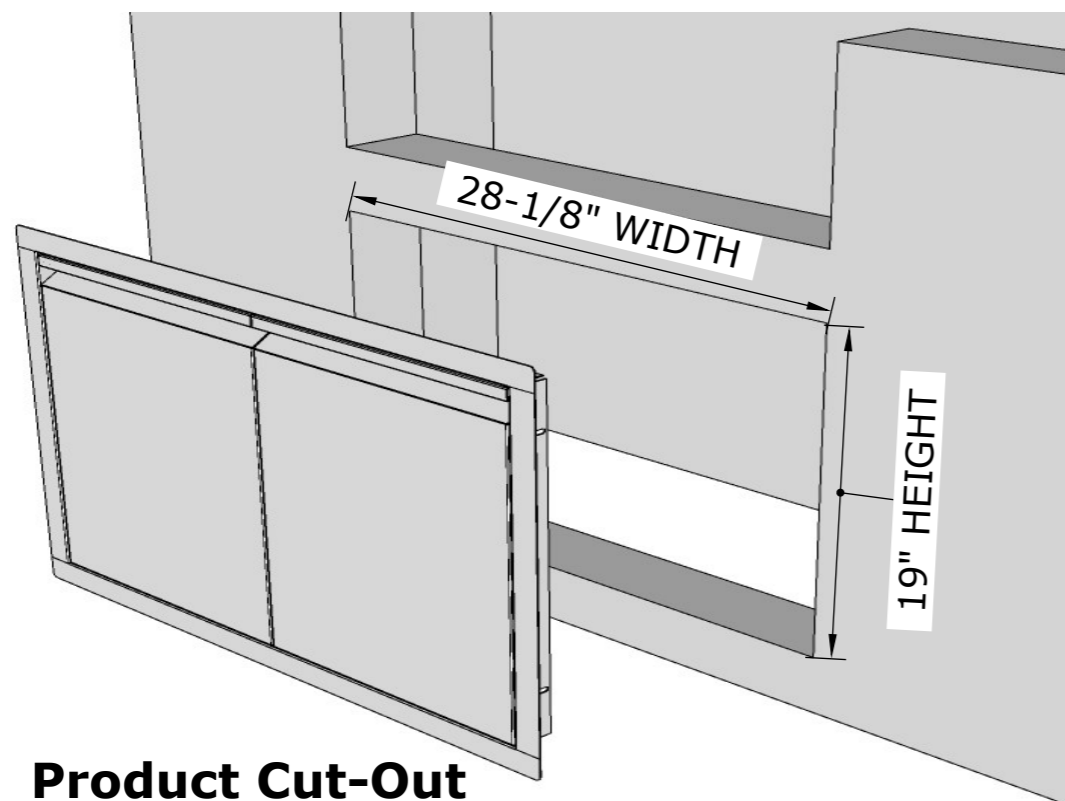

OPEN SLOTS ALLOW FOR EASY INSTALLATION

HAVE COMPONENT ON SITE BEFORE MAKING ISLAND CUTS, CONFIRM ALL DIMENSIONS BEFORE CUTTING INTO ISLAND WALL

MOUNT TO INTERIOR ISLAND CUT-OUT EDGE USING SCREW CONSISTENT WITH YOUR INSTALLATION TYPE. CONCRETE, MASONRY, WOOD, METAL ALL USE DIFFERENT SCREW TYPES (HARDWARE NOT INCLUDED)

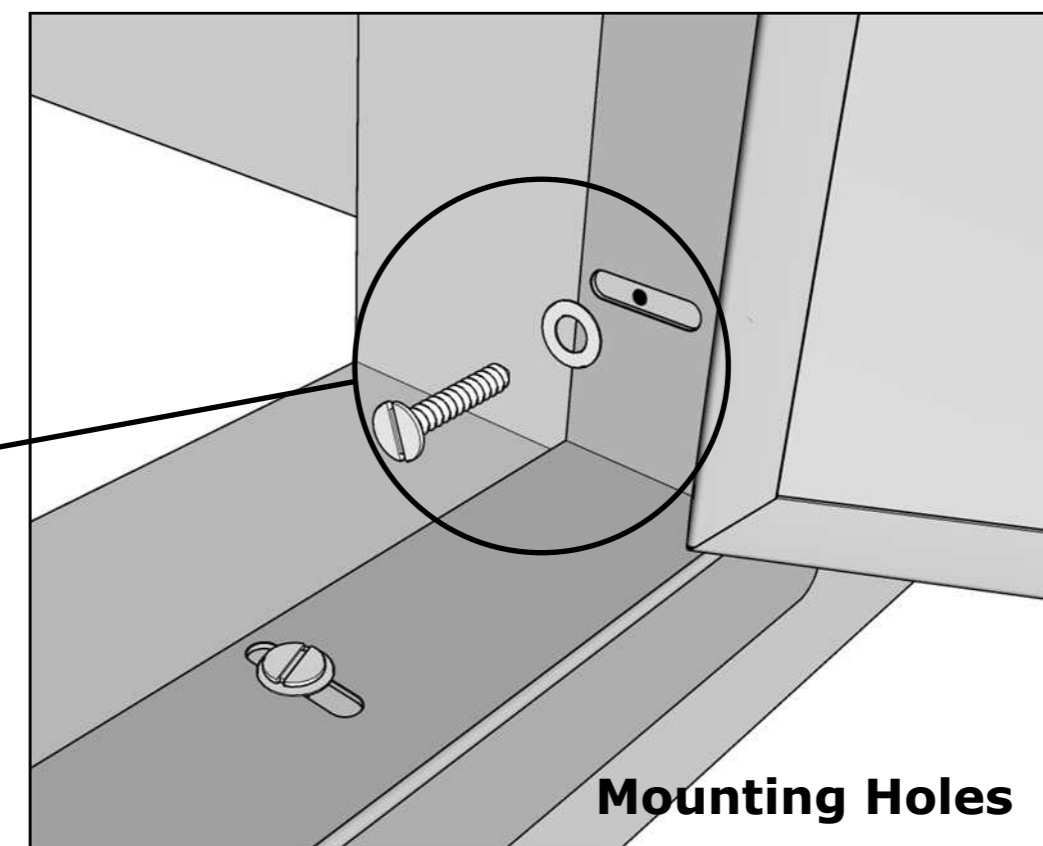

### Product Cut-Out