

ARUBA SERIES ODK COMPONENTS

PRODUCT

16" Trash Drawer
w/Bin Included

Item No. ARU-16TRD

DESCRIPTION

16" Aruba Series Large Trash
Drawer with a ABS Trash Bin
Included

PRODUCT DIMENSIONS

Product Size: 16-1/4" WIDTH x
20-1/2" HEIGHT x 21" DEPTH
Cut-Out Size: 14-3/8" WIDTH x
19" HEIGHT x 21-1/4" DEPTH

SPECIFICATIONS

304 Stainless Steel
Construction Drawer, 201 SS
Cabinet Box (Not Exposed to
Elements)

WARRANTY

3 YEARS STRUCTURE
WARRANTY AGAINST
MANUFACTURE DEFECTS

Product Dimensions

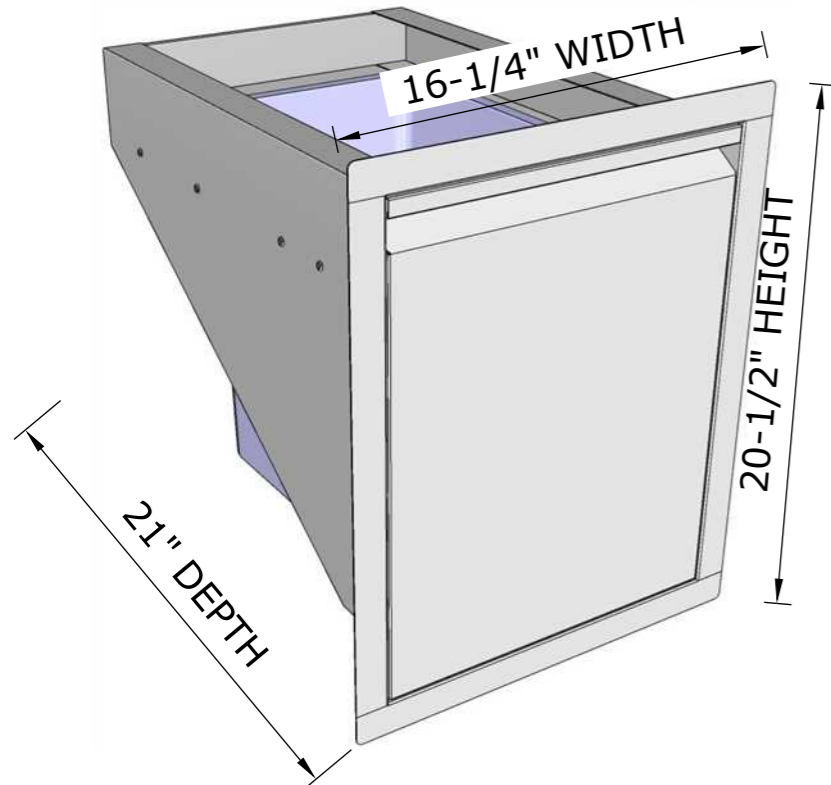

Mounting Holes

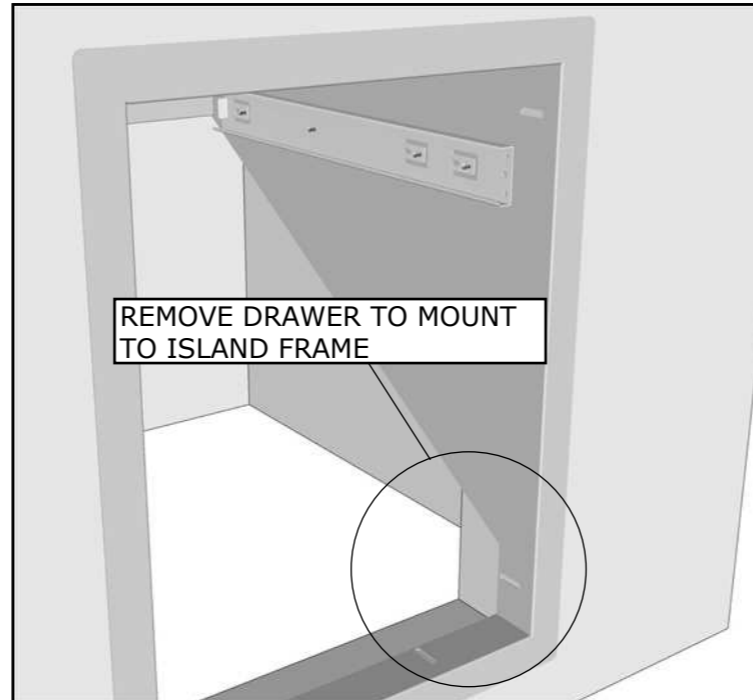

HAVE COMPONENT ON SITE BEFORE MAKING ISLAND CUTS,
CONFIRM ALL DIMENSIONS BEFORE CUTTING INTO ISLAND WALL

ONLY NEED TO SECURE FRAME TO INTERIOR ISLAND, THE BOX
DOES NOT NEED SUPPORTED

REMOVE THE TRASH DRAWER TO ACCESS THE INSTALLATION
SLOTS, BE SURE TO SECURE ALL SIDES.

MOUNT TO INTERIOR ISLAND CUT-OUT EDGE USING SCREW
CONSISTENT WITH YOUR INSTALLATION TYPE. CONCRETE,
MASONRY, WOOD, METAL ALL USE DIFFERENT SCREW TYPES
(HARDWARE NOT INCLUDED)

ISLAND WALL CUT-OUT SIZE:
14-3/8" WIDTH x 19" HEIGHT x 21-1/4" DEPTH

Product Features

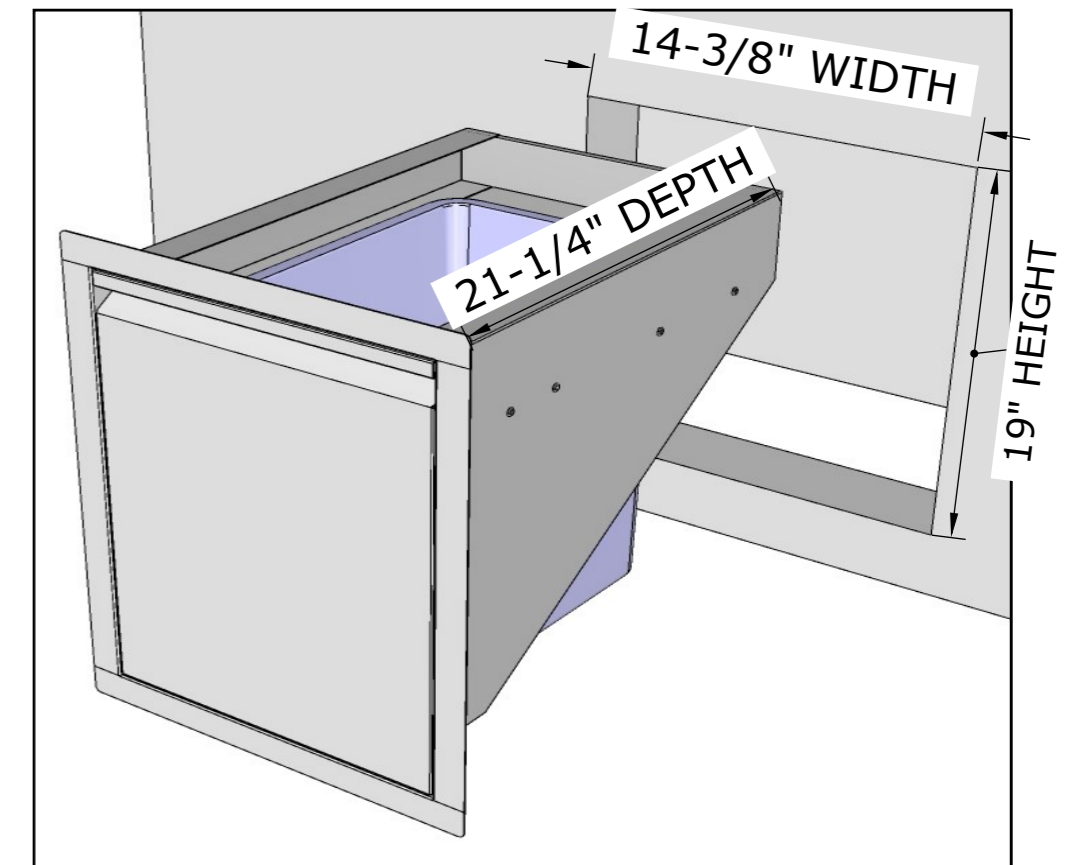
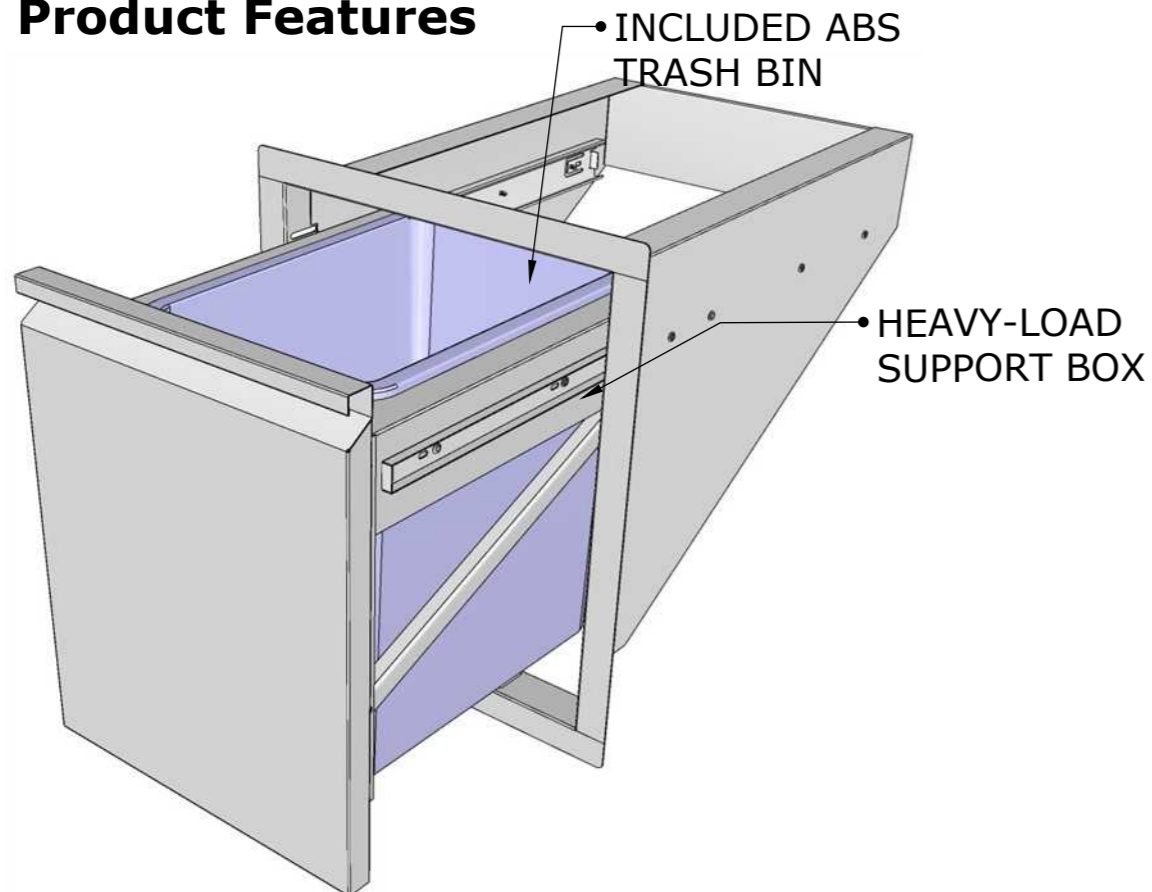

Product Cut-Out